



Battery Motor – Radio Drive

ERBS15LE - Series

Compatible with:

- Control Station SI7002
- Remote Controller SIS1600, SIS1602, SIS1605
- Solar Panel SI1288H
- Sun Sensor SIS1187

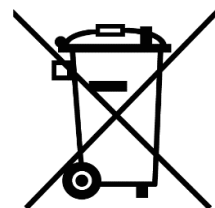

1. General safety guidelines



Notes on the product

- Check the drive for intactness. Do not use the product if you discover any damage. In this case, contact the point of sale.
- Only use the drive to open and close suitable hangings.
- Read this manual completely before starting the installation.
- Make sure that the roller blind's tube, in which you intend to use the drive, is undamaged.
- Check that the blind can be opened and closed smoothly.
- Replace damaged parts if you find any defects.
- Inform all persons in safe use of the controls and the drive.
- Observe the blind during the operation and keep people away until the blind is fully opened or closed.
- Do not allow children to play with the control unit.



2. Connection and installation

- The distance between the drive and the transmitter should be at least 300 mm.
- The distance between two remote control receivers should be at least 500 mm.
- Strong, local transmitters (e.g. radio headphones), whose transmission frequency is identical to the control (433MHz), can influence the function.
- It is recommended to fully charge the drive before the initial installation. Only then will the motor reach full power. The drive is equipped with a control display which allows you to monitor the charge level at any time. The control display flashes when charging. If the light is continuously red, the actuator is fully charged. You can remove the charging cable.
- The engine can also be operated and programmed during charging.

Mains connection at motor head:



3. Programming of the remote control (radio) transmitters

3.1 Check the connection between the engine and transmitter

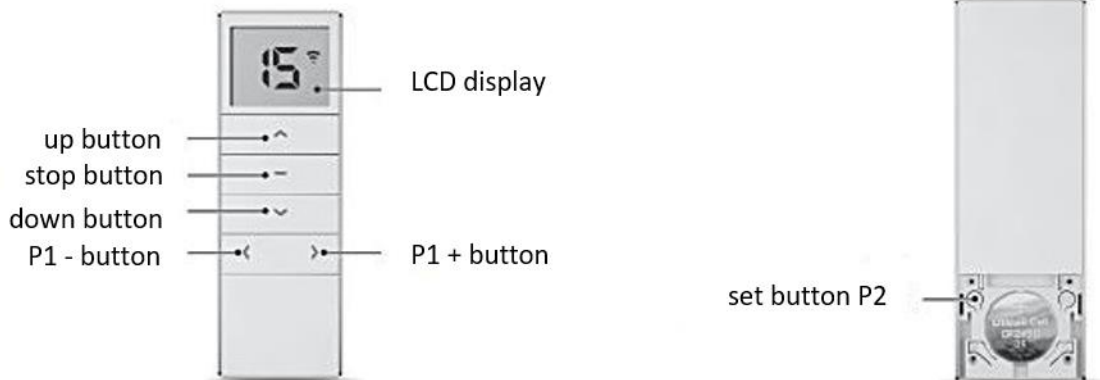

1. Test the connection between the handheld transmitter (remote controller) and the motor by pressing the **up** or **down button** to move the drive up or down. If the connection exists, please go directly to point 3.3.
2. If the motor does not move, you must first establish the connection between the motor and the transmitter.

Important: For all programming, please only use the left P2 button as shown.

3.2 Establishing and deleting the connection between the motor and the remote controller

Establish connection:

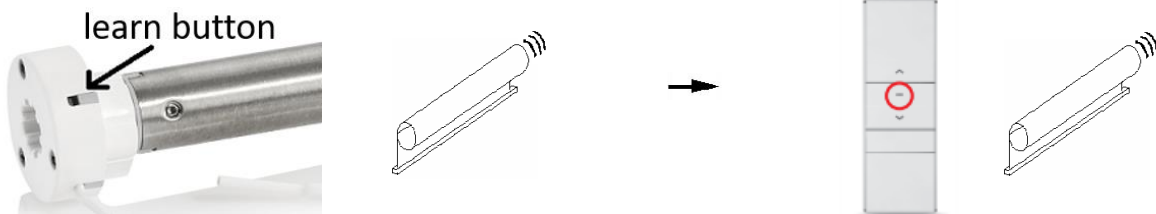

1. Press and hold the **learn button** on the motor head with an object until the drive reacts only once (usually after 3 seconds) with a short up/down movement. Release the learn button immediately.

2. Specify a channel. Press and hold the **stop button** on the remote controller, up to 10 seconds, until the drive responds with two up/down movements.

The connection from the drive to the remote controller is thus established. You can now control the drive by pressing the **up** and **down buttons** on the remote controller.

Initially, the drive moves only step by step when the **up/down button** is pressed briefly. If you press the button for a long time, the drive then moves permanently. Once the end positions have been set, the mode of operation then changes automatically to permanent mode.

Delete connection:

If the end positions are already set (**important!**), the connection between motor and remote controller can be deleted by completing the same operations as for *Establish connection*.

3.3 Check and change the direction of rotation of the drive

Important: Please ensure the direction of rotation before starting to input the motor. We are not liable for product damage caused by negligence during installation.

If the direction of rotation is reversed, there are two ways to change this

1. Using the remote controller:

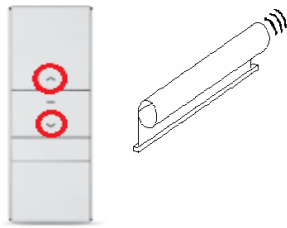

Keep the **up** and **down buttons** pressed simultaneously until the drive reacts with short up/down movements. Release the buttons again. This changes the direction of rotation of the motor.

Important: Please note that this change must be made before setting the end positions. Otherwise, you need to re-teach the remote controller.

2. Using the motor:



Press and hold the **learn button** on the motor head with an object until the drive reacts 3 times with short up/down movements. Release the learn button immediately. This changes the direction of rotation.

This method can also be used after the end position has been set.

4. Installation of the motor



- Do not hit the motor with hard object – not even to push it into the roller blind's tube. This can cause damage to the drive and the shaft.
- Avoid installing the motor in damp places or places where it encounters water.

Installation

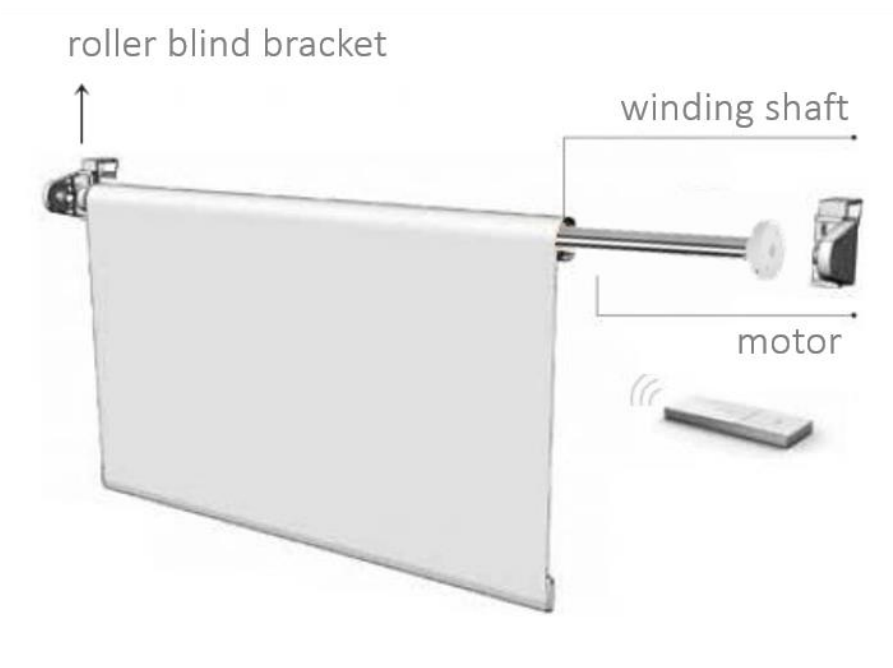

- Place the motor into the shaft using the appropriate adapter set.
- Driver and adapter must be completely inserted into the shaft. If necessary, the adapter must first be pushed into the groove provided for this purpose on the crown of the motor head
- The head of the motor can be installed either on the right or on the left side.
- When installing the motor, make sure that the head of the motor remains freely accessible for charging after installation.

5. Setting the end positions



- You need to define the upper and lower end positions, when reaching these, the drive switches off automatically. To do this, the drive system must be fully inserted.
- You can choose whether to set the lower or upper end position first.
- The time between each button combination should not exceed 6 seconds. Otherwise, the setting status is aborted.



With some roller blind fabrics, enormous temperature fluctuations cause the fabric length to change. Depending on the fabric and overall length, in extreme cases, there can be a shortening in cold weathers and a lengthening at high temperatures, which can even be in the centimetre range. Especially for cassette systems it is absolutely necessary not to parameterize the upper end position up to the stop but to leave at least 1 cm clearance!

Setting the end position: The setting of the upper end position is shown in the following.

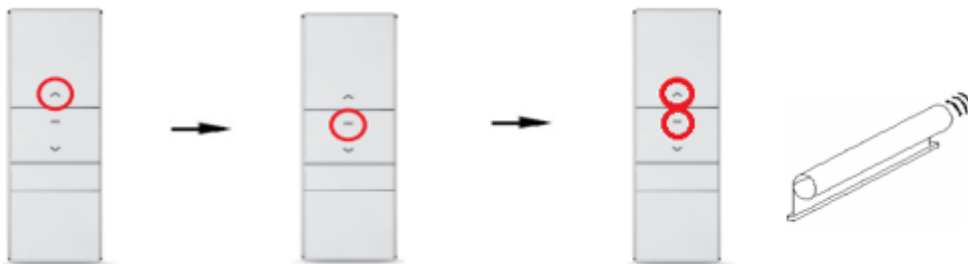

1. Press the **up button** and let the drive move upwards.

2. Press the **stop button** when the motor has reached the desired upper end position.

3. Press and hold the **up** and **stop buttons** simultaneously until the motor reacts with two up/down movements. Release the buttons again.

Thus, the upper end position is set. The setting of the lower end position is analogous by replacing the **up button** with the **down button**. If both end positions are set, the drive will automatically stop at the respective end positions during operations.

Changing the end position (option): The following shows how to change the upper end position.

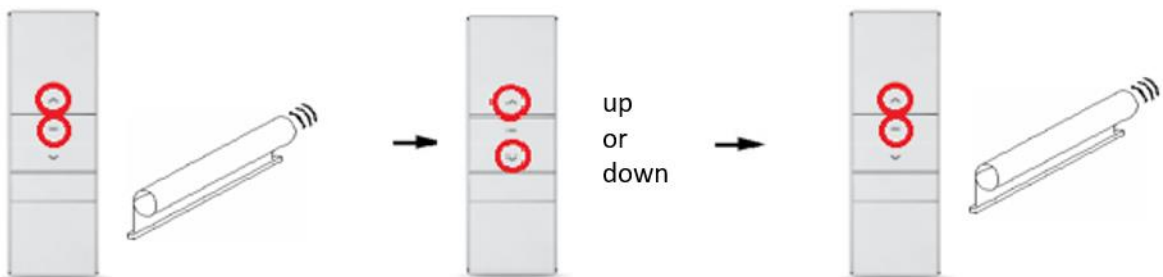

1. Press and hold the **up** and **stop buttons** simultaneously until the drive reacts with a single up/down movement. Release the buttons again.

2. Then move the drive to the new desired end position using the **up** and **down buttons**.

3. Press and hold the **up** and **stop buttons** simultaneously again until the drive reacts with two up/down movements. Release the buttons.

Thus, the upper end position is changed. You can also change the lower end position in the same way.

6. Setting a desired middle position (optional)



- You can set a middle position of your choice as an option.
- The middle position can only be set after the two end positions have been set.

Setting the desired middle position:

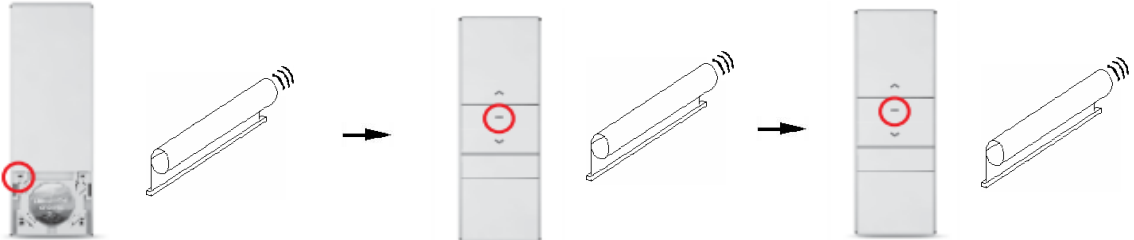

1. Move the drive to the desired middle position. Press the **P2 button** once. The drive confirms with an up/down movement.

2. Then press the **stop button** once. The drive confirms with an up/down movement.

3. Press the **stop button** again. The drive confirms with two up/down movements.

The middle position is now set. You can move your drive to this position by pressing and holding the **stop button**.

Deleting the middle position:

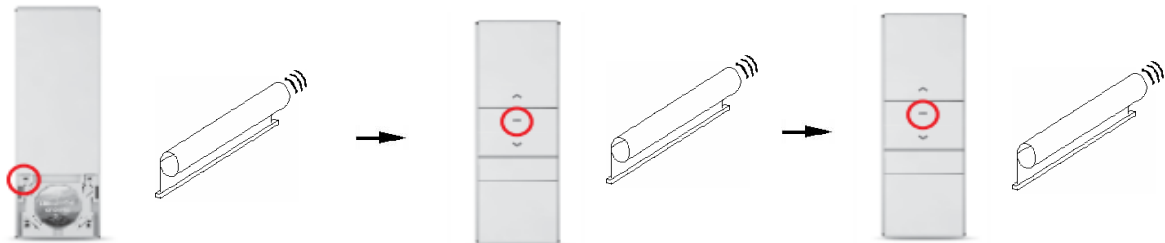

1. Move the drive to the middle position. Press the **P2 button** once. The drive confirms with an up/down movement.

2. Then press the **stop button** once. The drive confirms with an up/down movement.

3. Press the **stop button** again. The drive confirms with one up/down movement.

The middle position is hereby deleted.

7. Reset to factory settings



Press and hold the **learn button** on the motor head with an object until the drive reacts only 4 times with a short up/down movement. Release the **learn button** again. The motor is now set to the factory settings. All previous connections and settings are deleted.

8. Technical data

Technical data	
Power supply:	USB
Protection class:	IP22
Operating temperature:	0°C to +50°C

Definition	Diameter D (mm)	Length L (mm)	Torque (Nm)	Rotational speed (U/min)	Performance (W)	Power input (mA)	Weight (g)
ERBS15LE	16	370	0,3	30	5	600	150

9. Bug fixing

Problem	Possible cause	Solution
Drive does not run	Battery weak	Charge the drive via the mains connection on the motor head with the micro -USB charging cable.
	Remote controller without function	Change to a new battery.
	Transmitter is not set up	Establish the connection between the motor and the transmitter (see 3.2).
Drive is very slow, even with charged battery	Incorrect installation	Make sure that the shaft, materials and drive can move freely.
	Overloading	Check the loaded weight.
Drive stops in-between both end positions	Adapter or roller capsule not positioned correctly	Check that the adapter is correctly seated on the groove provided in the crown and, if necessary, screw the roller capsule into the shaft with a locking screw.
The end position changes marginally	Fabric changes due to temperature differences	Reset end position (see 5).

10. Warranty conditions

SIRO Antriebs- und Steuerungstechnik offers a 2-year warranty on new drives that have been professionally installed and properly operated in accordance with the installation instructions. The warranty covers all design faults, material defects and manufacturing faults.

Any defects occurring within the warranty period will be remedied by SIRO free of charge by supplying an equivalent or new product. Replacement delivery for warranty reasons does not result in general extensions of the original warranty period.

Any claims for compensation beyond this are excluded.